

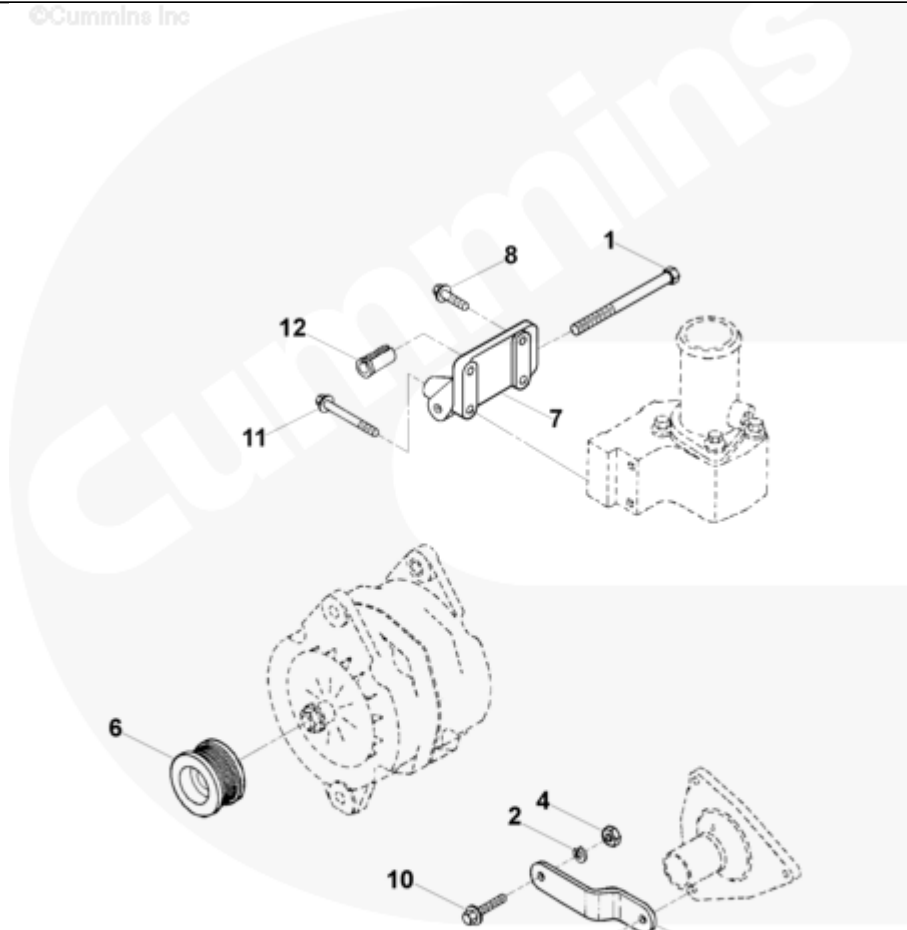

Parts Catalog - Option Detail

Electronic Parts Catalog - Option Detail				
Option	Group	Graphic	Film Card	Date
EH9079-03	13.02.3	eh920gs	Z	15-OCT-98
Engines	6C8.3, C GAS PLUS CM556, G8.3, G8.3 CM558, GTA8.3 CM558, ISC CM2150, ISC CM554, ISC CM850, ISC8.3 CM2250, ISC8.3 G CM2180 C101, ISL CM2150, ISL CM554, ISL CM850, ISL G CM2180, ISL8.9 CM2150 L110, ISL8.9 CM2880 L112, ISL9 CM2150 SN, ISL9 CM2250, ISL9 CM2350 L101, ISL9 CM2350 L111, ISLE4 CM850, L GAS PLUS CM556, L8.9, L8.9 L121, L8.9G CMOH2.0 L125B, L9 CM2350 L116B, L9 CM2350 L119B, L9 CM2350 L120C, L9 CM2350 L123B, L9.3 L105, L9.5 L117, L9N CM2380 L124B, QSC8.3 CM2250, QSC8.3 CM2880 C102, QSC8.3 CM554, QSC8.3 CM850(CM2850), QSL9 CM2250, QSL9 CM2250 L115, QSL9 CM2350 L102, QSL9 CM2350 L107, QSL9 CM2350 L118, QSL9 CM2350 L122, QSL9 CM554, QSL9 CM850(CM2850), QSL9 G CM558, QSL9 M CM2250 L106, QSL9.3 CM2880 L113			



eh920gs

[SMALL](#) | [MEDIUM](#) | [LARGE](#)

Cart	Ref No	Part Number	Part Description	Required	Remarks
View My Cart					
		EH9079-03	Alternator Location		MR - ALTERNATOR LOCATION...(More)
					Alternator Manufacturer /
					Model: CAV AC5RSM
					Engine Design Phase: Current
					Product
					Pulley Retainer Provided: No
					Alternator Pulley Provided:
					Yes
					Belt Supplier: Cummins
					Belt Tensioner Supplier:
					Cummins
					Alternator Drive Speed: 2.9
					Alternator Mount Type: 4
					Inch Hinge
					Damper Pulley Effective
					Diameter (mm): 173.76
					Alternator Driven by Auxilary
					Belt: No
					Required Tensioner Pulley
					Material: Steel
					Pad for Freon Compressor
					Provided: No
					Engine Family: C Series
					Required Water Pump Pulley
					Type: Standard
					Stud for Wiring Harness
					Attachment: No
					Alternator Tail Support

					Required: No
					REF. Compressor Mounting
					Hardware Included: No
					Tall Tensioner Bracket: No
<input type="checkbox"/>	1	S 153	Hexagon Head Cap Screw	1	7/16 - 14 X 5 in.
<input type="checkbox"/>	2	S 605	Lock Washer	1	5/16 in.
<input type="checkbox"/>	3	S 626	Plain Washer	1	5/16 in.
<input type="checkbox"/>	4	3900240	Regular Hexagon Nut	1	M8 X 1.25.
<input type="checkbox"/>	5	3276799	Alternator Brace	1	
<input type="checkbox"/>	6	3281531	Alternator Pulley	1	
<input type="checkbox"/>	7	3280811	Alternator Support	1	
<input type="checkbox"/>	8	3900631	Hexagon Flange Head Cap Screw	2	M8 X 1.25 X 25.
<input type="checkbox"/>	9	3902114	Hexagon Flange Head Cap Screw	1	M8 X 1.25 X 30.
<input type="checkbox"/>	10	3928873	Hexagon Flange Head Cap Screw	1	M8 x 1.25 x 40
<input type="checkbox"/>	11	3903096	Hexagon Flange Head Cap Screw	2	M8 X 1.25 X 70.
<input type="checkbox"/>	12	3906755	Mounting Spacer	1	